

## Unit Switch

- The unit switch button is located at the bottom of the scale.
- Press the unit switch button to select your desired unit from "kg" (kilo gram) to "lb" (pound) or to "公斤" (kilo gram) when the monitor displays "0.0".

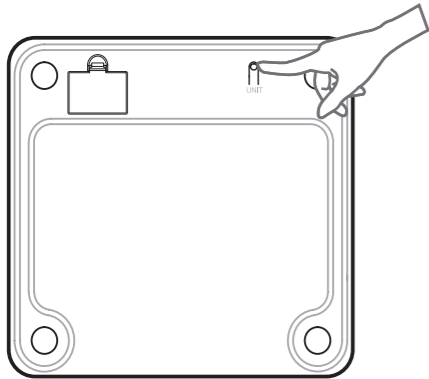

## How to Take a Measurement

### Step 1

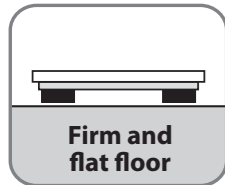

Firm and flat floor

Put the scale on the firm and flat floor, avoid cushioned floor surface such as a carpet or mat. Please refer to "Data Transfer via Bluetooth" section for first time use.

### Step 2

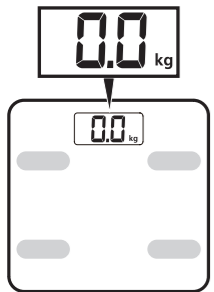

Turn the APP of smartphone on, step on the scale gently, it will turn on automatically. The LCD display will show 0.0 kg(lb) and Bluetooth symbol. The Bluetooth symbol (⌘) will illuminate on the display after successful connection with smartphone, if not, [ ] will illuminate, the subsequent measured readings (max. 10 readings) will be temporarily stored in the device and transmitted to APP automatically until next successful connection.

### Step 3



Step onto measurement platform carefully with bare feet on the electrodes (stainless steel area) of the monitor and remain stationary until the measured reading stop flashing after completion of the measurement.

## Step 4

The measured reading (weight) will blink twice and lock on LCD display. Check your measured values (body weight, body fat in %, muscle in %, visceral fat level, BMR and BMI) from the APP.

### Note:

- Before 0.0 kg appears, please don't step on the monitor. Without further activity the monitor will automatically power-off in 15 seconds.
- Unpairing your device will not delete the data from the APP.
- If you re-pair your smartphone with the device, all prior reading history stored on the phone APP will be retained.
- Bluetooth data transfer will reduce the battery capacity.
- Electromagnetic interference: Avoid strong electrical or electromagnetic fields in the direct vicinity of the device.

## Data Transfer via Bluetooth

Pairing the device with your Smartphone for first time use. Please visit the website at [www.rossmax.com](http://www.rossmax.com) for the initial set-up instructions.

- Download and install the applicable APP onto your smartphone.
- Set up your personal data on the APP.
- Turn Bluetooth and the APP of smartphone on, and follow the setup and pairing instructions.
- The Bluetooth symbol (⌘) will illuminate on the display that indicates the pairing is done.

- If the pairing is successful, once the measurement is done, the current measured reading will automatically be transferred to the APP and your measured values will also be shown on the APP at the same time.
- If the pairing has failed, the symbol [ ] will be shown on the display, and the current measured values will not automatically be transferred to the APP. Please re-pair this device with your smartphone.

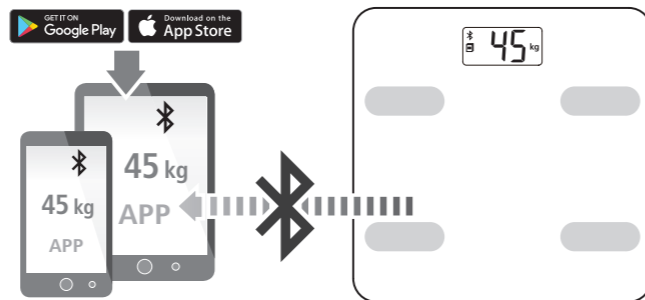

## Care and Maintenance

- Clean the scale only by using a slightly damp cloth.
- Do not use solvents or abrasive cleaning agents.
- Do not submerge the scale under water.
- Store the scale in a dry location and keep it horizontal.
- Do not expose the scale to direct sunlight.
- Place the unit gently and avoid strong shocks, such as dropping the unit on the floor.

## Error Messages and Troubleshooting

Error messages	Possible causes	Correction
No display appears	Battery flat or no battery.	Replace the batteries with the intended type (3 x AAA).
	Battery is not installed or inserted properly.	Re-insert the batteries in the correct positions.
	The weight is less than auto-on value.	Step on the scale or press it hard to meet auto-on value (5-15kg).
Lo	Low battery.	Replace the batteries with the intended type (3 x AAA).
[ ]	The weight value is above the measurement range.	The maximum measurement capacity is 150 kg. Please remove the critical load to avoid load cell damage.
[ ]	Measurement error.	Please follow the measurement steps and try again.
[ ]	Data transmit failure.	Connect this device with your smartphone and transfer again.

## Technical Data

Capacity x Graduation	5-150kg x 100g
Accuracy	50kg ± 0.4kg; 100kg ± 0.5kg; 150kg ± 0.6kg
Display resolution	Body fat/Body muscle: 0.1%
Body fat	5-80% ±2
Body muscle	25-90% ±2
Measurement unit	Kg/lb/公斤
Dimensions	Approx. 300 x 270 x 22mm
Batteries	AAA*3
Auto-on value	5-15Kg
Operation condition	5-40°C, ≤85%RH, 80 - 106kPa
Storage condition	-20-55°C, ≤90%RH, 50 - 106kPa

rossmax

Model: WF262



## EN Bluetooth Body Fat Scale

### Healthstyle APP



Data Transfer via Bluetooth  
Please download and install the free Healthstyle APP onto your smartphone



[www.rossmax.com](http://www.rossmax.com)

### Warranty Card

This instrument is covered by a 2 year guarantee from the date of purchase, batteries and accessories are not included. The guarantee is valid only on presentation of the warranty card completed or stamped by the seller/dealer confirming date of purchase or the receipt. Opening or altering the instrument invalidates the guarantee. The guarantee does not cover damage, accidents or non-compliance with the instruction manual. Please contact your local seller/dealer or buying source or [www.rossmax.com](http://www.rossmax.com).

Customer Name: \_\_\_\_\_

Address: \_\_\_\_\_

Telephone: \_\_\_\_\_

E-mail address: \_\_\_\_\_

Product Information

Date of purchase: \_\_\_\_\_

Store where purchased: \_\_\_\_\_

**WARNING:** The symbol on this product means that it's an electronic product and following the European directive 2012/19/EU the electronic products have to be disposed on your local recycling centre for safe treatment.

Manufacturer: Rossmax Swiss GmbH,  
Widnauerstrasse 1, CH-9435 Heerbrugg, Switzerland  
[www.rossmax.com](http://www.rossmax.com)



OBM\_IR\_WF262\_ EN\_SW\_ver2010 INSWF26200000010

## Introduction

Thank you for your decision to purchase Rossmax bluetooth body fat scale. Please peruse this instruction manual prior to first start up and keep this user instruction careful so as to have this information on hand whenever it is needed.

## Safety Guidelines

The monitor is not intended for use by persons (including children) with reduced physical, sensory, or mental capabilities, or lack of experience and knowledge, unless a person responsible for their safety has given them supervision or instruction concerning use of the scale. Children should be supervised to ensure that they do not play with the scale.

### ⚠ Cautions

- Do not use the scale if you have implanted medical equipment, such as cardiac pacemaker. A very low electrical signal passes through your body when taking a measurement, which may interfere with the operation of those medical equipments.
- Do not use the scale when you are using life support medical equipment or electronic medical equipment.
- Do not place the scale on a cushioned floor surface such as a carpet or mat. It may cause an incorrect measurement.
- Pregnant women should not use this device.
- Do not stand on the scale with wet feet or on a slippery surface of the weighing platform.
- People with disabilities should be assisted by the health care worker and/or the person who understand the information for use when using this device, or use a walker or other support device to prevent falling when stepping on and off the scale.
- Please avoid heavy object fall on the monitor. The glass surface is breakable.
- Do not step on the edge or jump on the measurement platform. You may lose your balance and fall that could cause injury. The device may be damaged.
- Do not service or maintain device while in use.
- Batteries can be fatal if swallowed. You should therefore store the batteries and products where they are inaccessible to children. If a battery has been swallowed, call a doctor immediately.
- This monitor is exclusive intended for private use but is not designed for commercial or professional use in hospitals or other medical facilities.

## Information on Body Composition

### What is BMI?

Body Mass Index (BMI) is a simple index of weight-for-height that is commonly used to classify underweight, overweight and obesity in adults. BMI uses the following simple formula to indicate the ratio between weight and height of a person.

$$\text{BMI} = \frac{\text{weight(kg)}}{\text{height(m)} * \text{height(m)}}$$

If the fat level revealed by BMI is higher than the international standard, there is an increased likelihood of common diseases. However, not all types of fat can be revealed by BMI.

BMI	Designation by the WHO
Below 18.5	Underweight
18.5 – 24.9	Normal weight
25.0 – 29.9	Pre-obesity
30.0 – 34.9	Obesity class I
35.0 – 39.9	Obesity class II
Above 40	Obesity class III

The above index refers to the values for obesity judgment proposed by WHO(World Health Organization).

### What is Body Fat Percentage?

The body fat content is shown as the amount of stored fat as a percentage of total body weight. There is no generally accepted set value as this varies significantly according to gender (due to the different build) and age.

Body fat is vital for basic body functions. It's protecting organs, cushioning joints, regulating body temperature, storing vitamins and serves the body as energy storage.

As essential for women a minimum body fat proportion between 10% and 13% and for men between 10% and 13% is requested with the exception of competitive athletes.

Body fat is not a clear indicator for health. Too high body weight and a too high body fat proportion are linked to the incidence of many civilization diseases such as diabetes, cardiovascular diseases, etc.

Lack of movement and improper nutrition are often the prime course for these diseases. There is an obvious direct relationship between overweight and lack of movement.

### Recommended Body Fat Ranges

Gender	Age	Under fat	Normal	Over fat	Obese
Female	20-39	< 21.0	21.0 - 32.9	33.0 - 38.9	≥39.0
	40-59	< 23.0	23.0 - 33.9	34.0 - 39.9	≥40.0
	60-79	< 24.0	24.0 - 35.9	36.0 - 41.9	≥42.0
Male	20-39	< 8.0	8.0 - 19.9	20.0 - 24.9	≥25.0
	40-59	< 11.0	11.0 - 21.9	22.0 - 27.9	≥28.0
	60-79	< 13.0	13.0 - 24.9	25.0 - 29.9	≥30.0

Based on Gallagher et al., American Journal of Clinical Nutrition, Vol. 72, Sept. 2000

## Body Fat Fluctuations in a Day

Hydration levels in the body may affect body fat readings. Readings are usually highest in the early waking hours, since the body tends to be dehydrated after a long night's sleep. For the most accurate reading, a person should take a body fat percentage readings at a consistent time of day under consistent conditions.

Besides this basic cycle of fluctuations in the daily body fat readings, variations may be caused by hydration changes in the body due to eating, drinking, menstruation, illness, exercising, and bathing. Daily body fat readings are unique to each person, and depend upon one's lifestyle, job and activities.

### What is Basal Metabolic Rate (BMR)?

Regardless of your activity level, a minimum level of caloric intake is required to sustain the body's everyday functions.

Known as the resting metabolism, this indicates how many calories you need to ingest in order to provide enough energy for your body to function.

### What is Visceral Fat?

Visceral fat is a type of body fat that's stored within the abdominal cavity. It's located near several vital organs, including the liver, stomach, and intestines. It can also build up in the arteries. It is different from fat found directly underneath the skin, which is referred to as subcutaneous fat. Visceral fat is sometimes referred to as "active fat" because it can actively increase the risk of serious health problems such as high cholesterol, heart disease and type 2 diabetes. In order to prevent or improve these conditions, it is important to try to reduce the amount of visceral fat levels to an acceptable level.

### Recommended Visceral Fat Ranges

Normal	High	Very High
Below 9	10-14	Above 15

## Name/Function of each parts

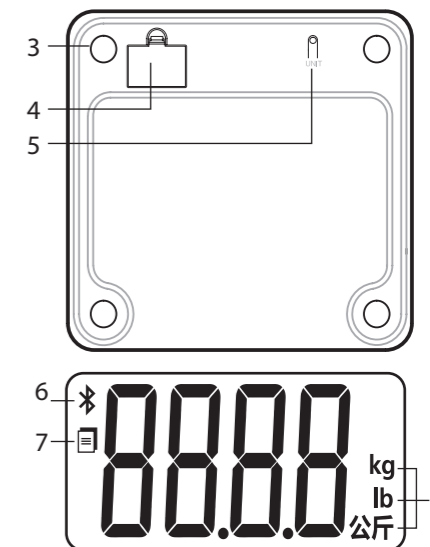
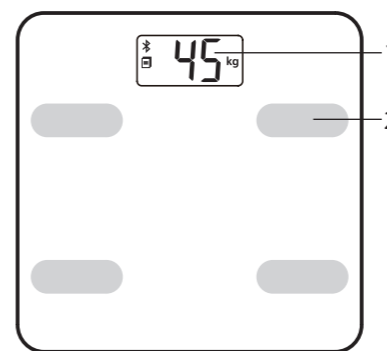

- |                          |                      |
|--------------------------|----------------------|
| 1. LCD Display           | 2. Electrodes        |
| 3. Sensor                | 4. Battery cover     |
| 5. Unit switch button    | 6. Bluetooth icon    |
| 7. Data transmit failure | 8. Measurement units |

## Preparation Before Use/Change Battery

- Remove the isolation sheet before using first time.
- Change the battery
  1. Press down and lift the battery cover to open the battery compartment.
  2. Replace 3 "AAA" sized batteries in battery compartment according to the indications inside the compartment.
  3. Replace the battery cover by clicking in the bottom hooks first, then push in the top end of the battery cover.
  4. Remove batteries when the unit is not in use for extended periods of time.

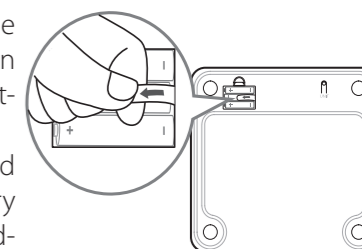

### ⚠ Cautions

1. Do not insert the batteries with their polarities incorrectly aligned.
2. Batteries are hazardous waste. Do not dispose them together with the household garbage.
3. Do not expose the batteries to flames or fire.
4. There are no user serviceable parts inside. Batteries or damage from old batteries are not covered by warranty.
5. Use exclusively brand batteries. Always replace with new batteries together. Use batteries with the same brand and same type.